

Food Amounts
Booklet

Interviewer
Copy

Food Amounts Booklet Conversion Guide for Dietary Interviewers

When the participant shows a picture in the Food Amounts Booklet, convert to NDSR amounts per the following information.

Squares and Rectangles 1/4 inch grid (pg 1)	Circles (pg 2)		
Enter as fractions, e.g., 9/4 wide x 12/4 long x 5/4 high or use page 4 for thickness. Each square is 1/4" x 1/4". Select shape, cube (3 dimensions) or rectangle (2 dimensions) per NDSR.	Select shape, circle or sphere. Enter diameter in inches (") per the following:		
	A = 1 inch B = 2 inches C = 2 1/2 inches	D = 3 inches E = 4 inches F = 5 inches	G = 6 inches H = 7 inches

Wedges (pg 3)						
STEP 1: Select the number that corresponds to the radius. Enter the radius in inches in NDSR	STEP 2: Find the number selected in step 1. Next, find the letter that matches to the length of the arc. Enter the number in inches you obtained as the width in NDSR					
1 = 4" radius (8" D ¹) 2 = 4 1/2" radius (9" D) 3 = 6" radius (12" D) 4 = 8" radius (16" D) 5 = 9" radius (18" D)		A	B	C	D	E
	1	0.6"	1.1"	2.1"	2.6"	3.9"
	2	0.7"	1.3"	2.4"	2.9"	4.4"
	3	0.9"	1.6"	3.1"	3.9"	5.9"
	4	1.1"	2.1"	4.1"	5.1"	7.8"
	5	1.3"	2.4"	4.7"	5.8"	8.9"
For 3D ² wedge, also use Thickness (pg 4, height=x/16) or Squares and Rectangles (pg 1, height=x/4)						

Thickness (pg 4)	Measuring Spoons (pg 5)	Eating and Serving Spoons (pg 6)	Measuring Cups (pg 7)
Each unit is 1/16" thick. Enter thickness as fraction. E.g.: 1 = 1/16" 2 = 2/16" 3 = 3/16" 18 = 18/16"	<u>Standard measures</u> 1/2 teaspoon (TS) 1 teaspoon 1/2 tablespoon (TB) 1 tablespoon	<u>Teaspoons:</u> Level = 1 TS Heaping = 2 TS <u>Tablespoon:</u> Level = 1 TB Heaping = 2 TB	Standard measures 1/4 cup (CP) 1/3 CP 1/2 CP 1 CP

Glasses (pg 8-9) (Fluid Ounces, FO)			
1 A = 1 1/4 FO 1 B = 2 1/2 FO 1 C = 3 3/4 FO 1 D = 5 FO	2 A = 2 1/2 FO 2 B = 5 FO 2 C = 7 1/2 FO 2 D = 10 FO	3 A = 3 FO 3 B = 6 FO 3 C = 9 FO 3 D = 12 FO	4 A = 8 FO (1 CP) 4 B = 16 FO (2 CP) 4 C = 24 FO (3 CP) 4 D = 32 FO (4 CP)

Bowls (pg 10-11)				Wine Glass (pg12)	Mug (pg 13)
1 A = 1/8 CP 1 B = 1/4 CP 1 C = 3/8 CP 1 D = 1/2 CP	2 A = 3/8 CP 2 B = 3/4 CP 2 C = 1 1/4 CP 2 D = 1 1/2 CP	3 A = 3/4 CP 3 B = 1 1/2 CP 3 C = 2 1/4 CP 3 D = 3 CP	4 A = 2 CP 4 B = 4 CP 4 C = 6 CP 4 D = 8 CP	A = 2 FO B = 4 FO C = 6 FO D = 8 FO	A = 2 1/2 FO B = 5 FO C = 7 1/2 FO D = 11 FO

Mounds (pg 14-15)	Meats (pg 16) (Ounces, OZ)	Chicken (pg 17) (Medium, MD)	Fish (pg 18)
1 = 1 CP 2 = 3/4 CP 3 = 1/2 CP 4 = 1/3 CP 5 = 1/4 CP	All are edible portion 1 = 3 OZ 2 = 3 OZ 3 = 1 1/2 OZ	Edible portion Wing = 1 MD Drumstick = 1 MD Thigh = 1 MD Breast = 1 MD	Edible portion 1 = 2 OZ 2 = 3 OZ 3 = 1/2 OZ 4 = 1 OZ

¹ D = Diameter

² 3D = three dimensional

Squares and Rectangles

A large grid for drawing squares and rectangles. The grid is 28 units wide and 37 units high. The horizontal axis is labeled with numbers 1 through 28 at the top and bottom. The vertical axis is labeled with numbers 1 through 37 on the left and right sides. An arrow points to the bottom-left corner of the grid with the text "Start Here".

Circles

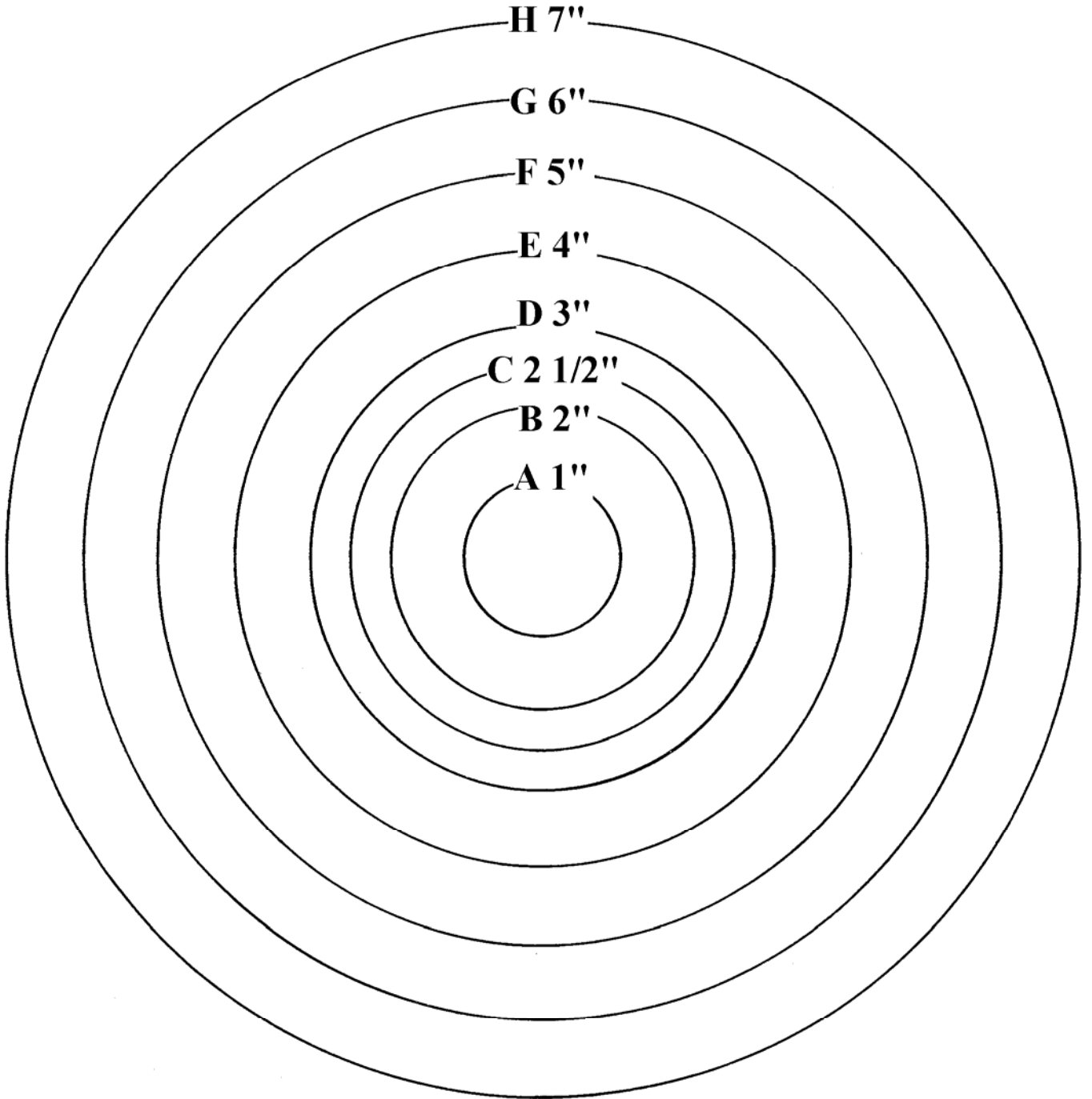

Wedges

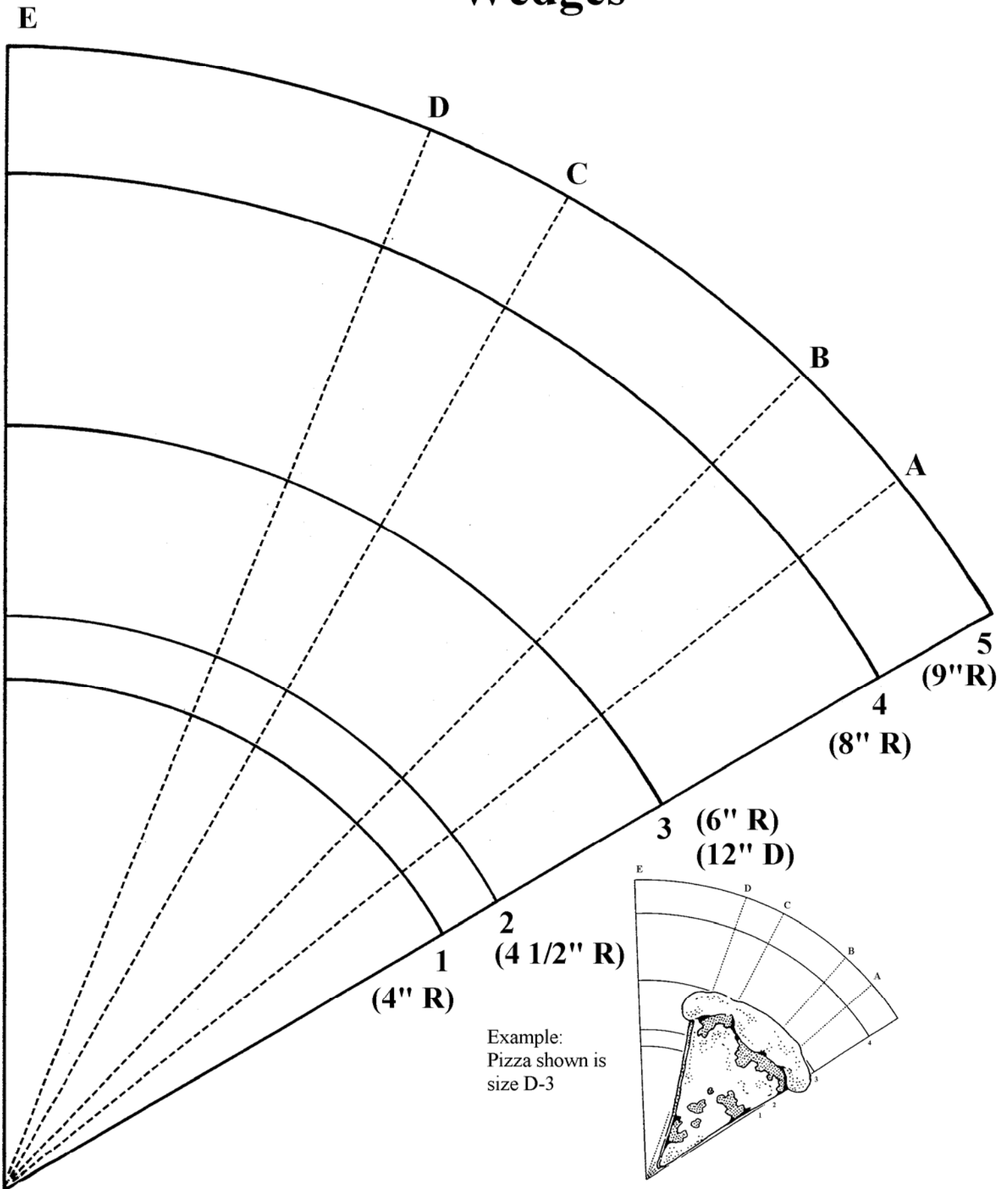

Thickness

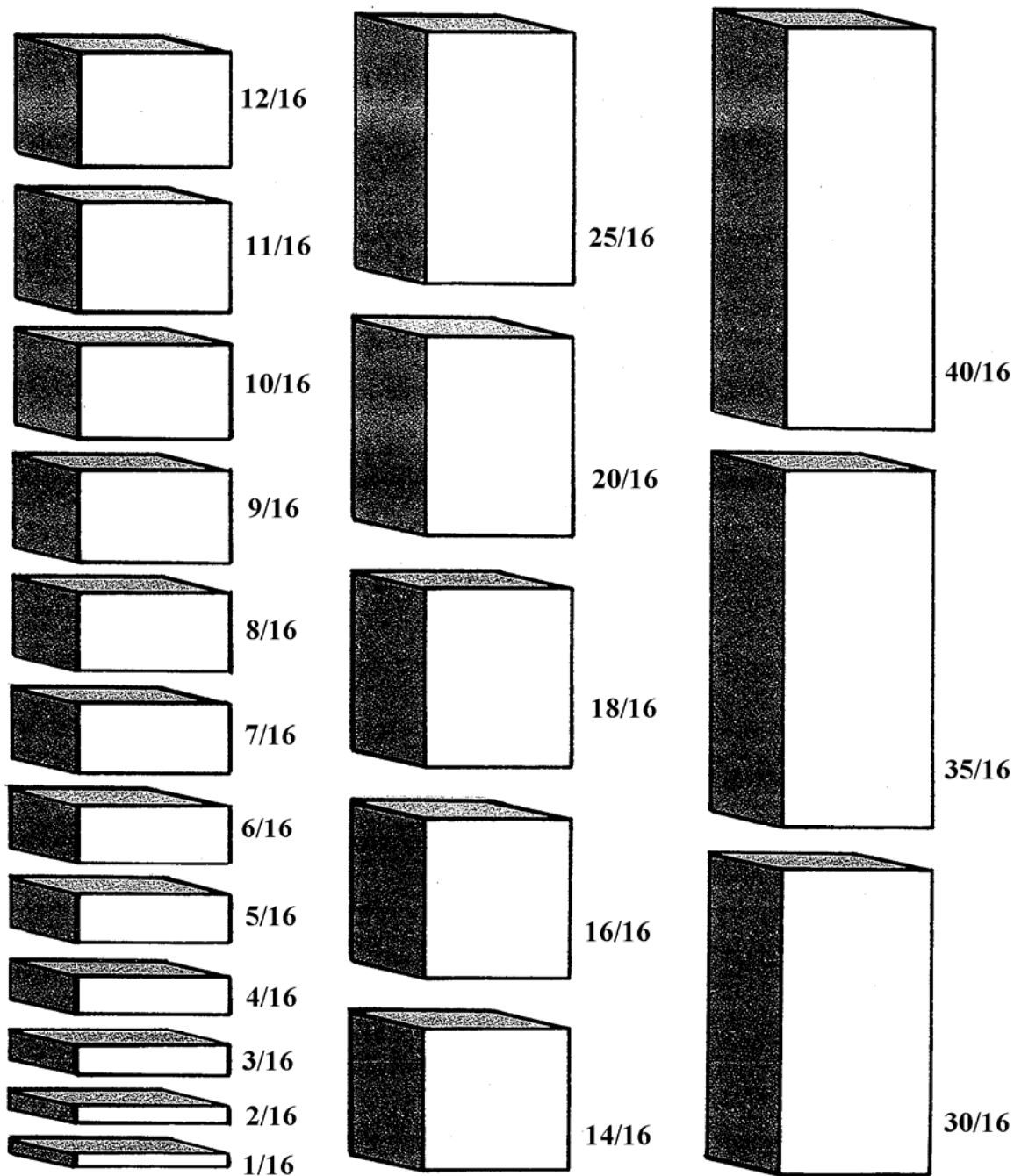

Measuring Spoons

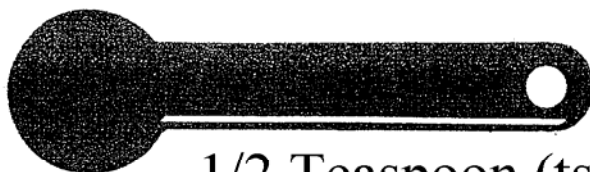

1/2 Teaspoon (tsp)



1 Teaspoon (tsp)



1/2 Tablespoon (Tbsp)



1 Tablespoon (Tbsp)

Eating and Serving Spoons

Teaspoons

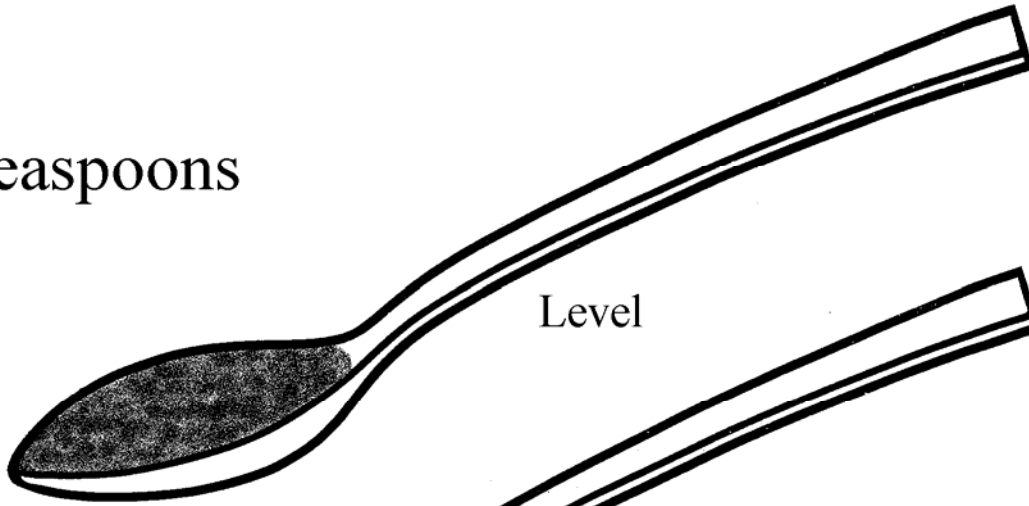

Level

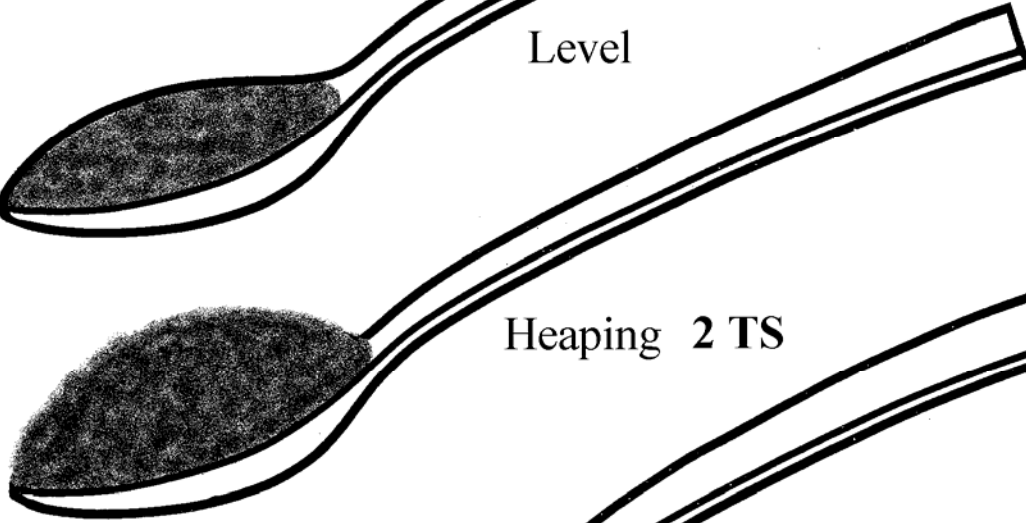

Heaping 2 TS

Tablespoons

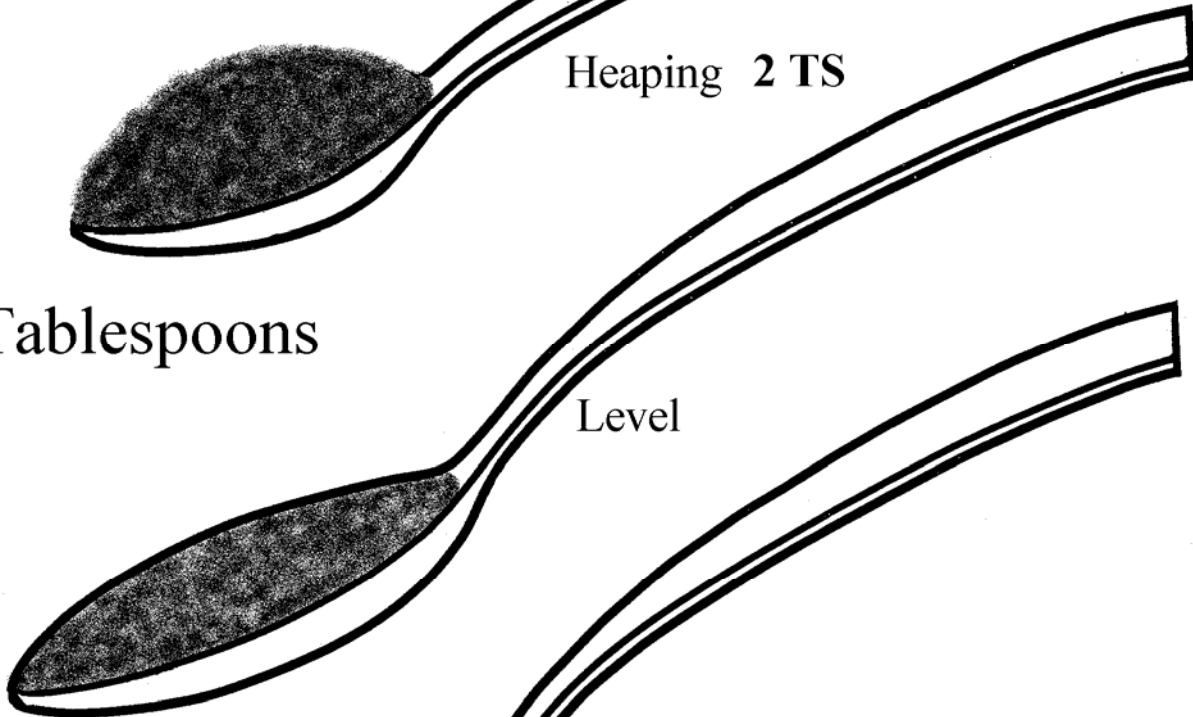

Level

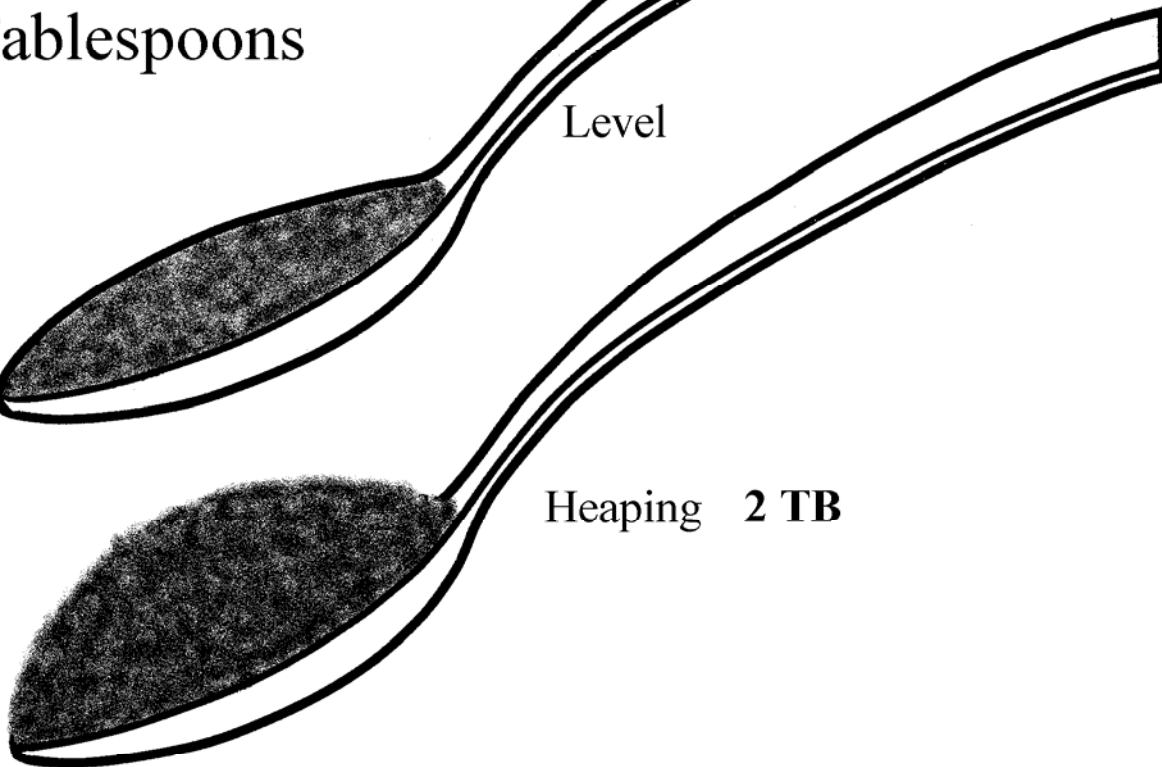

Heaping 2 TB

Measuring Cups

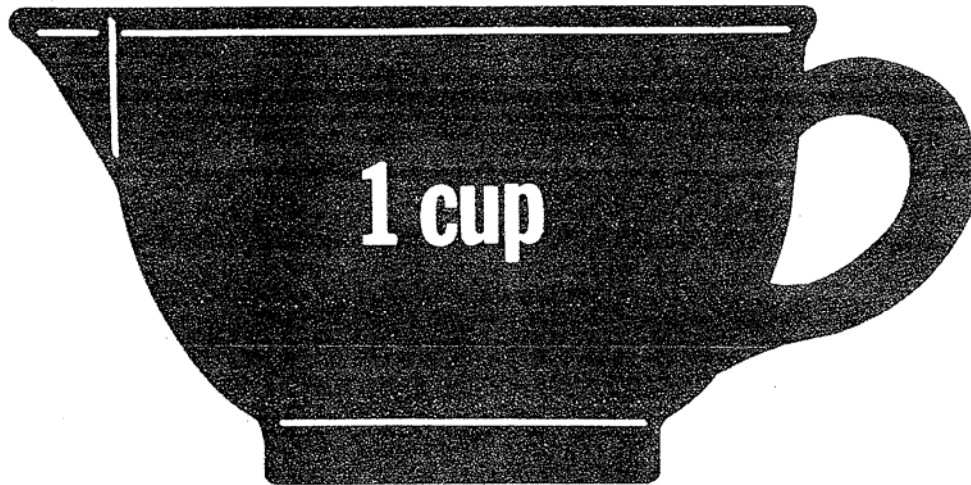
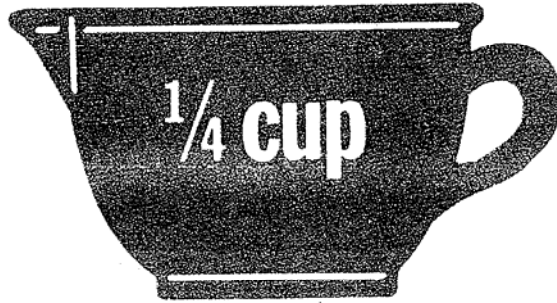

Glasses

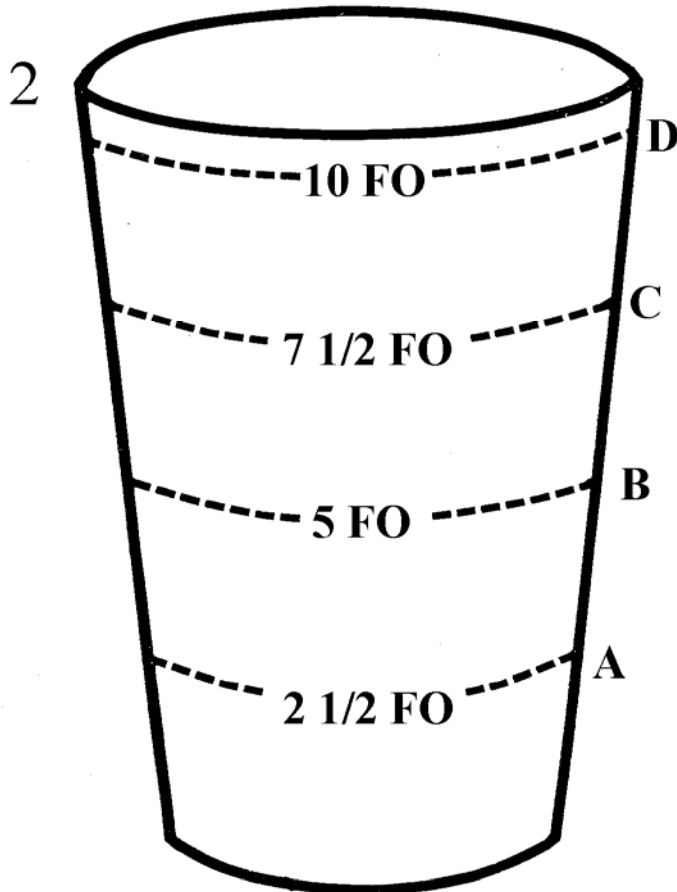
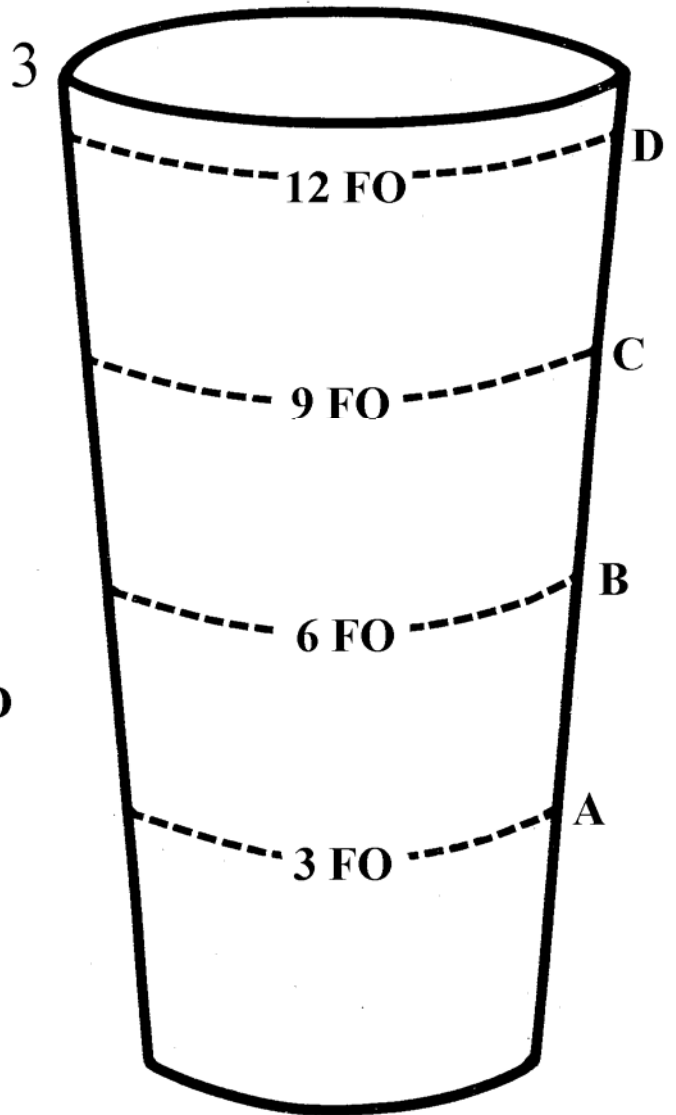
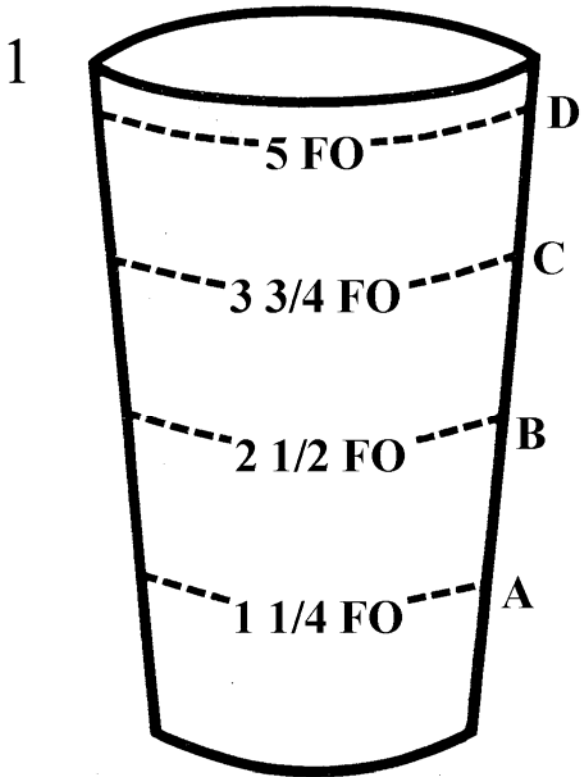

Glasses

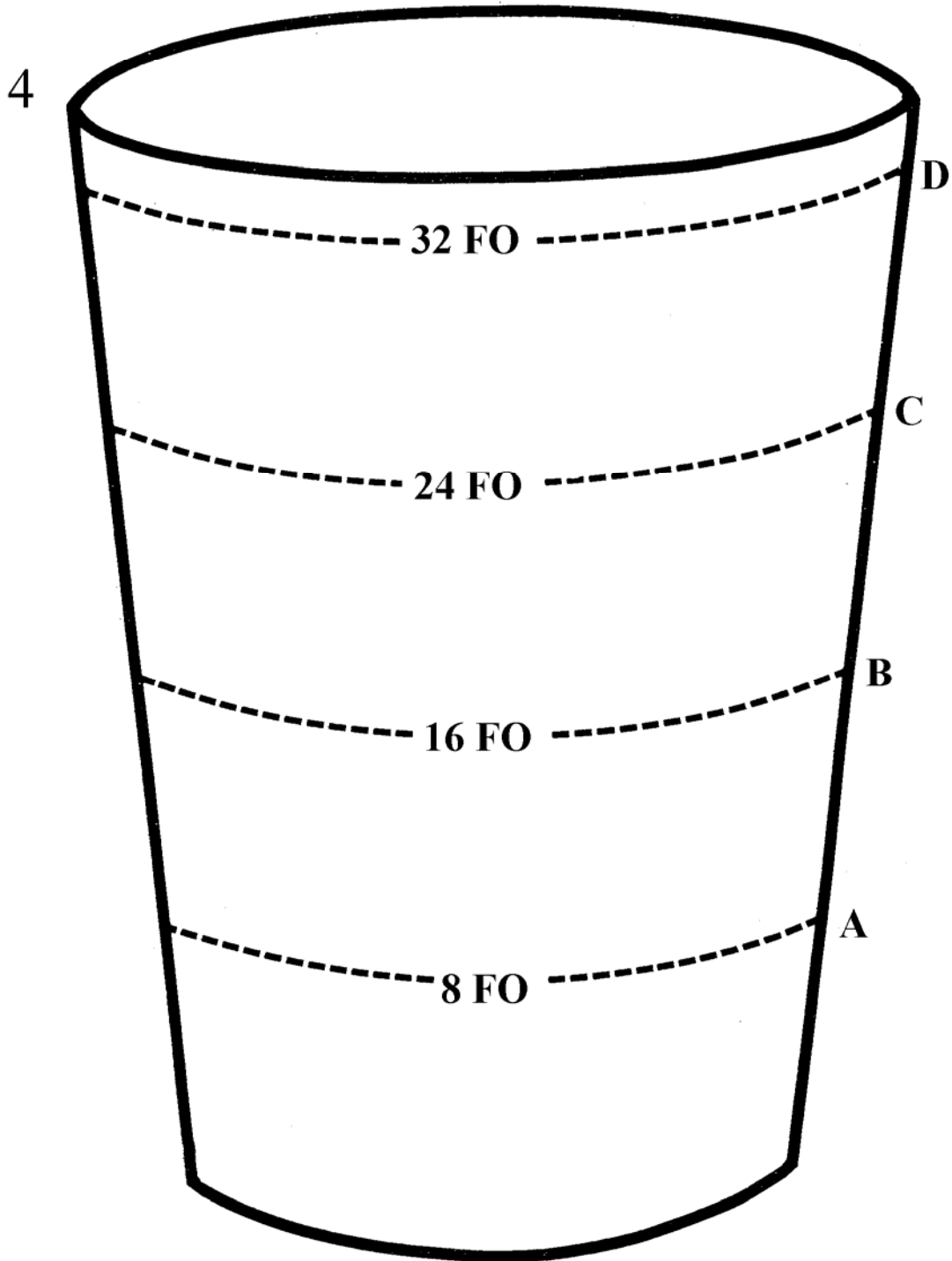

Bowls

1

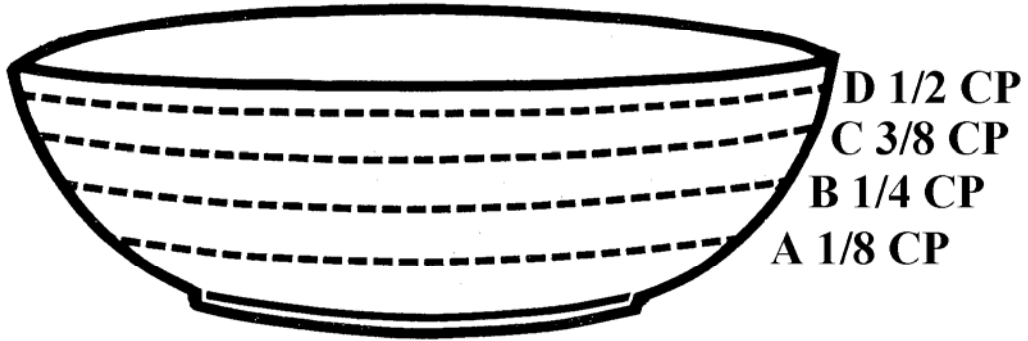

2

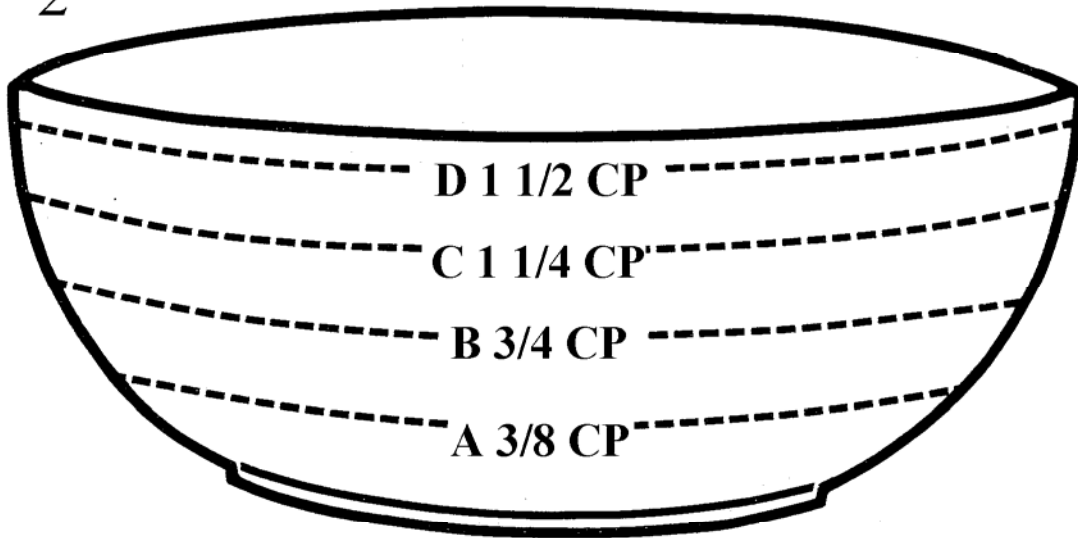

3

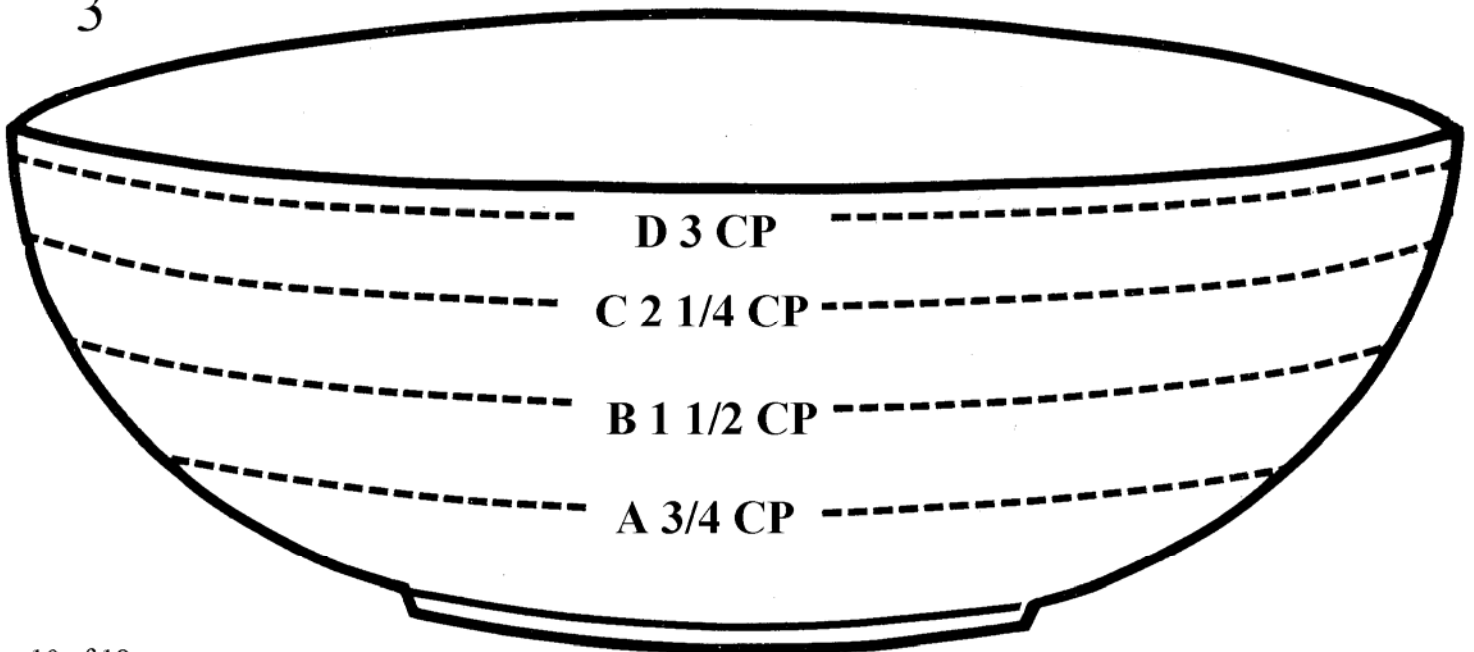

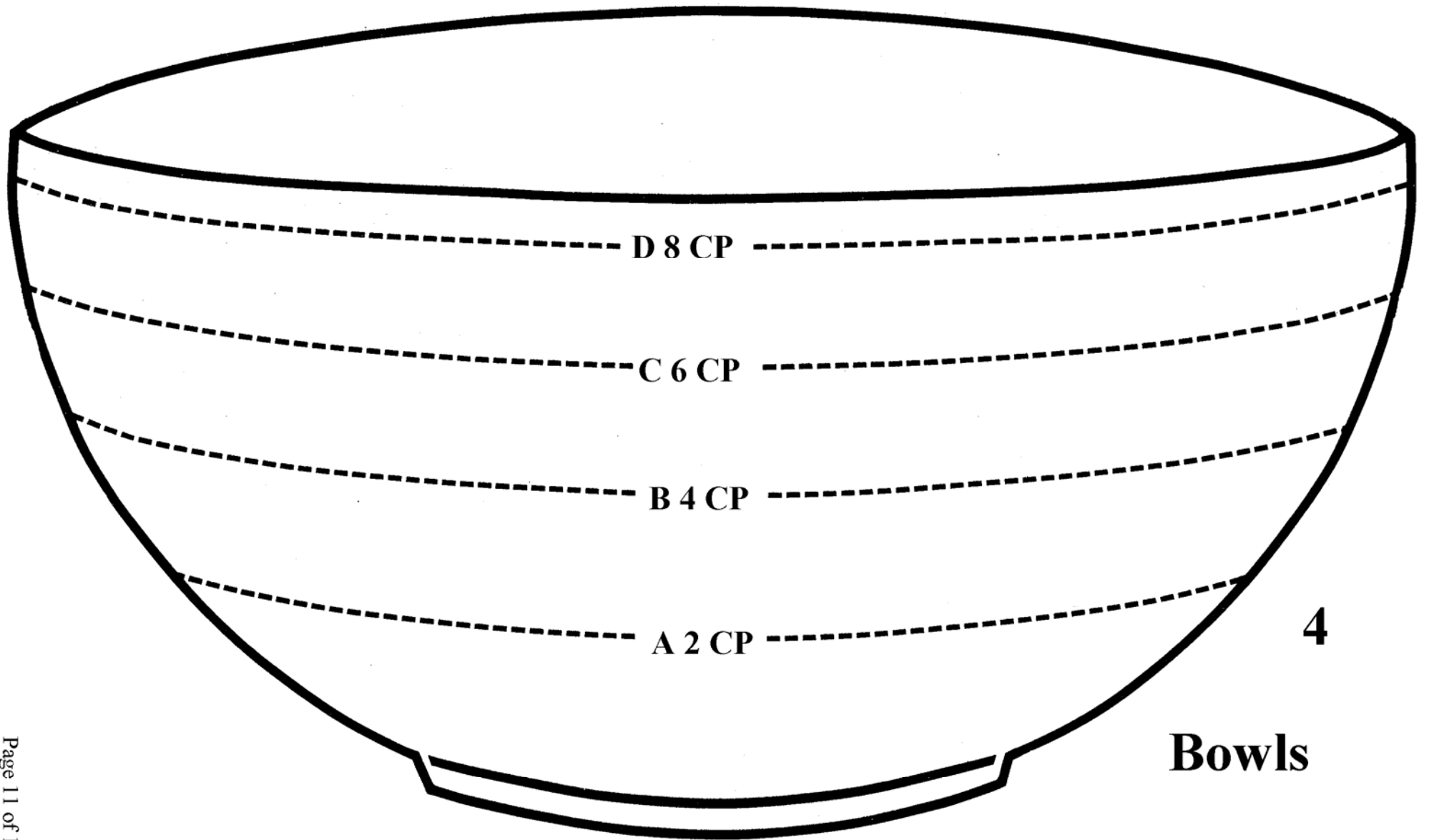

Wine Glass

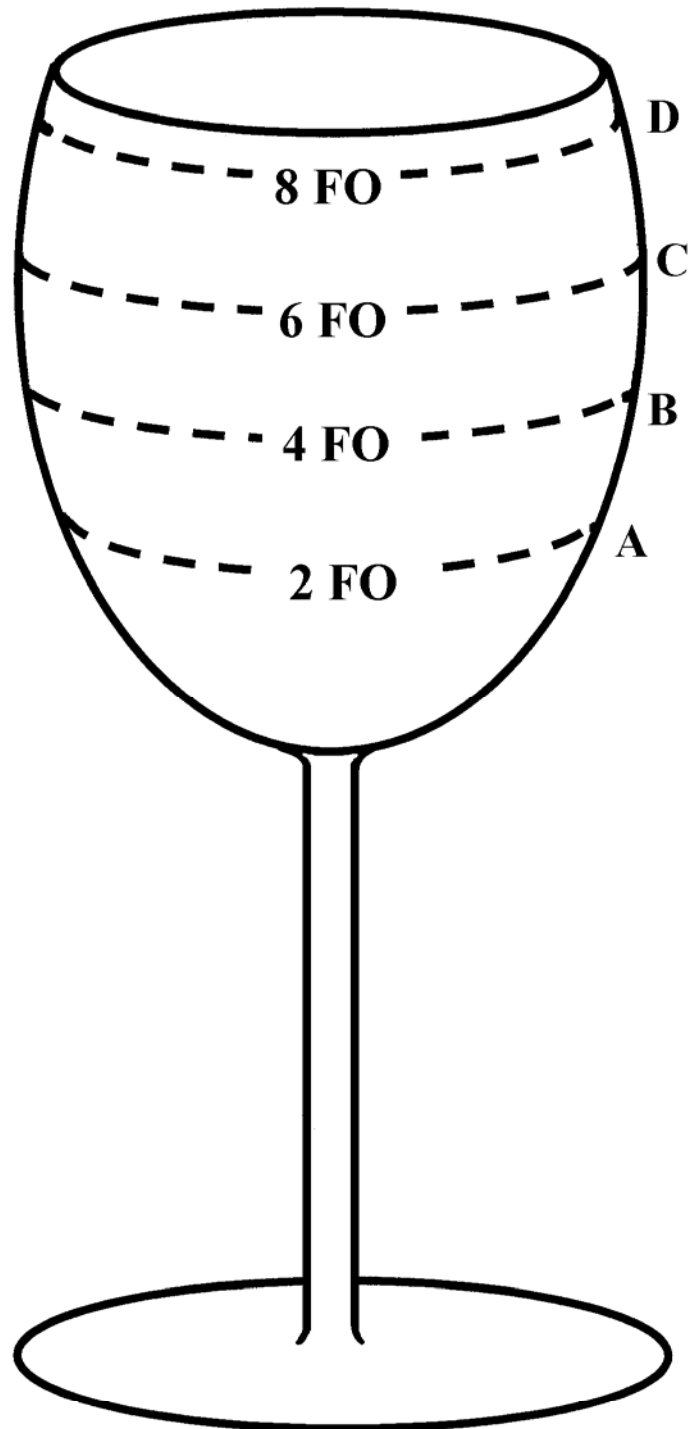

Mug

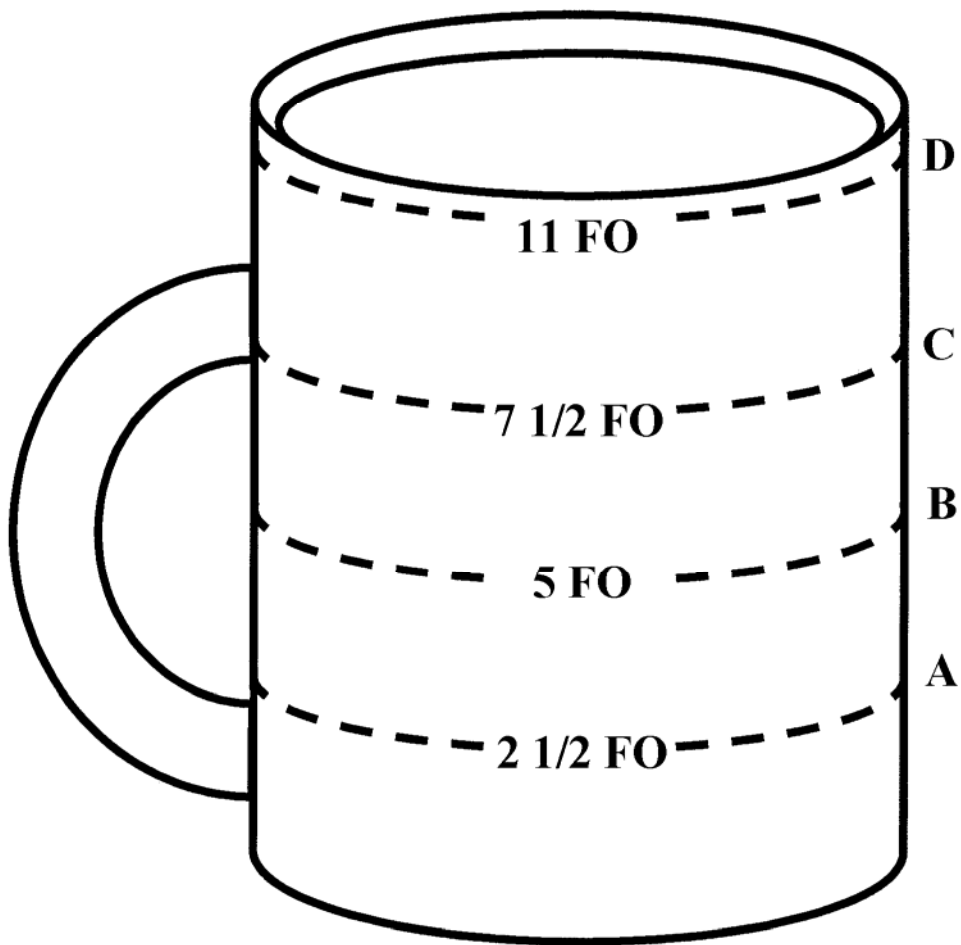

Mounds

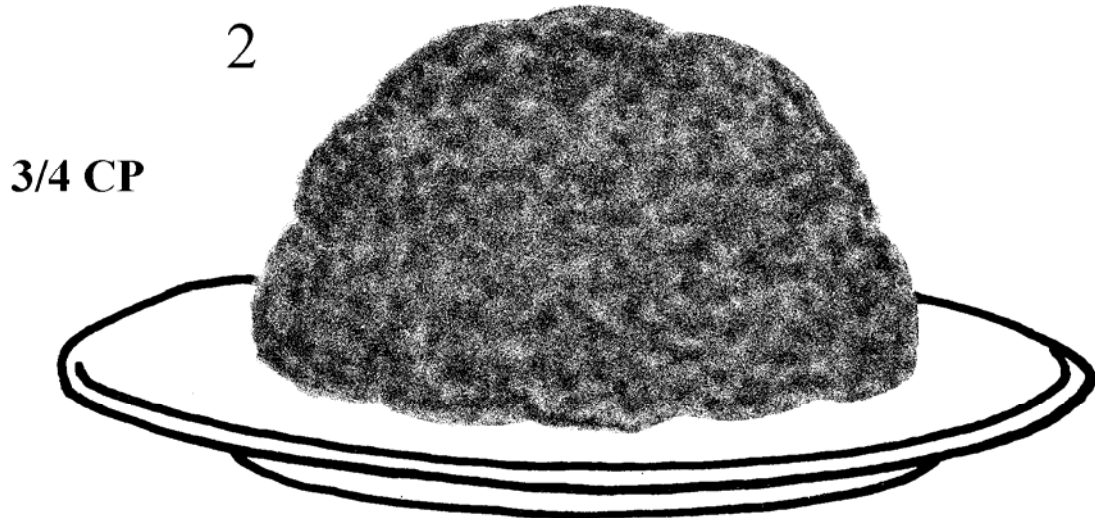
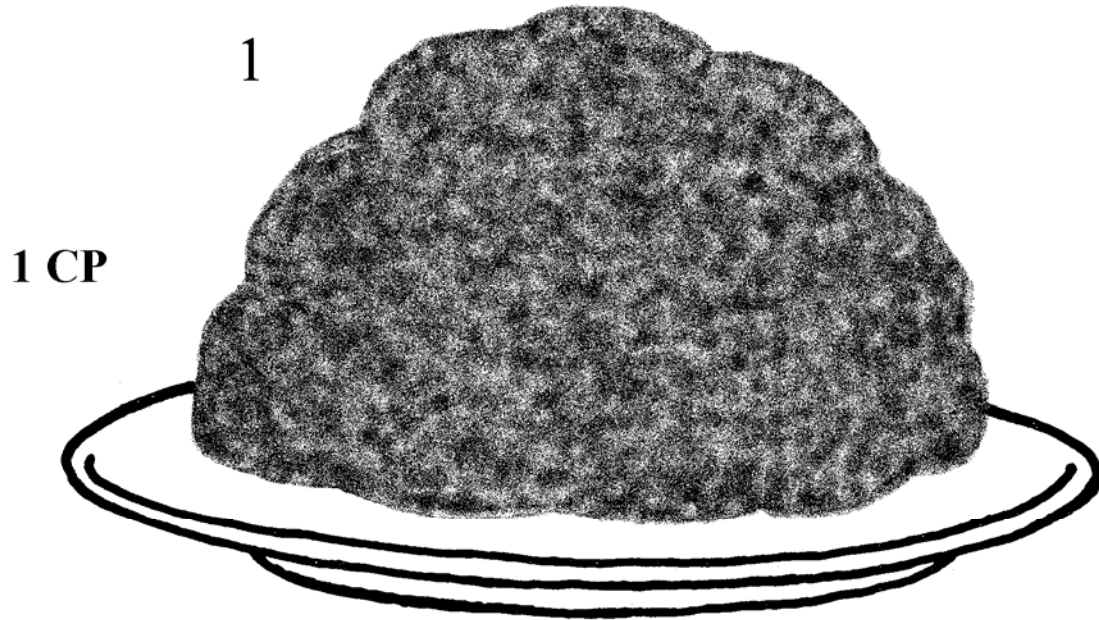

Mounds

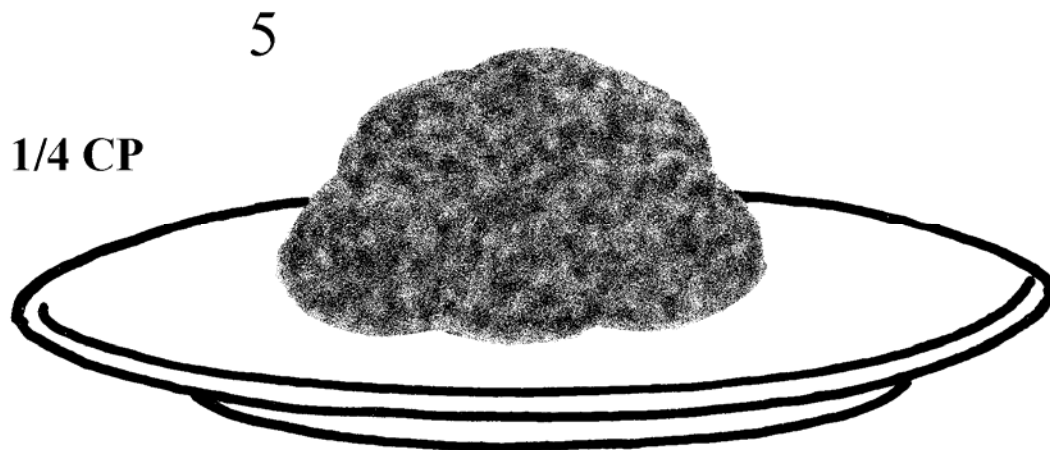
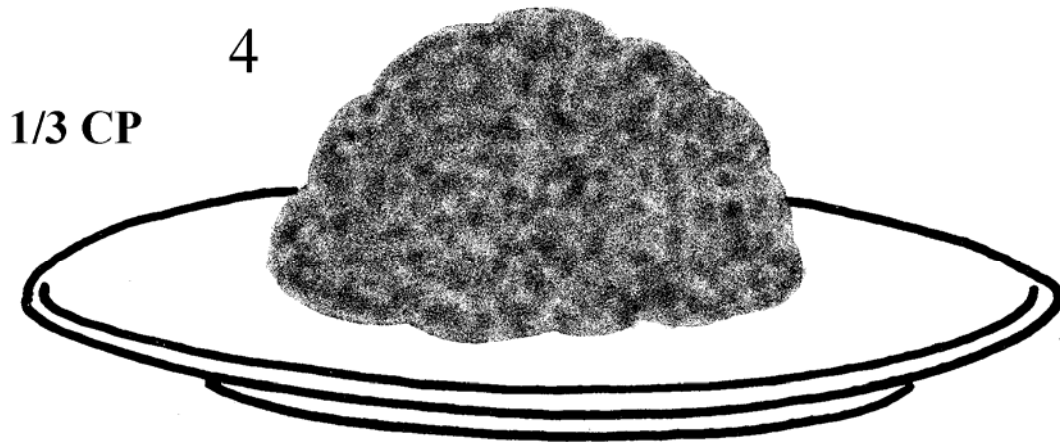
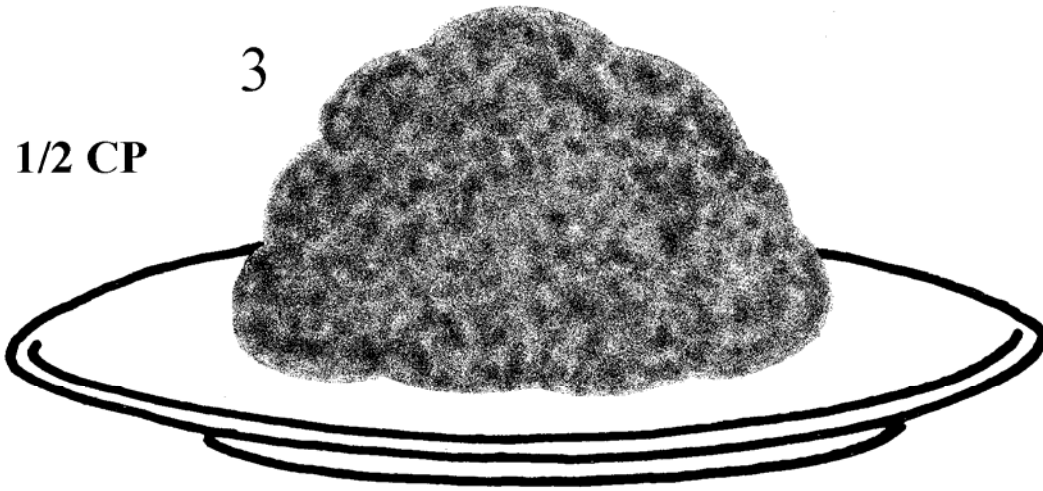

Meats

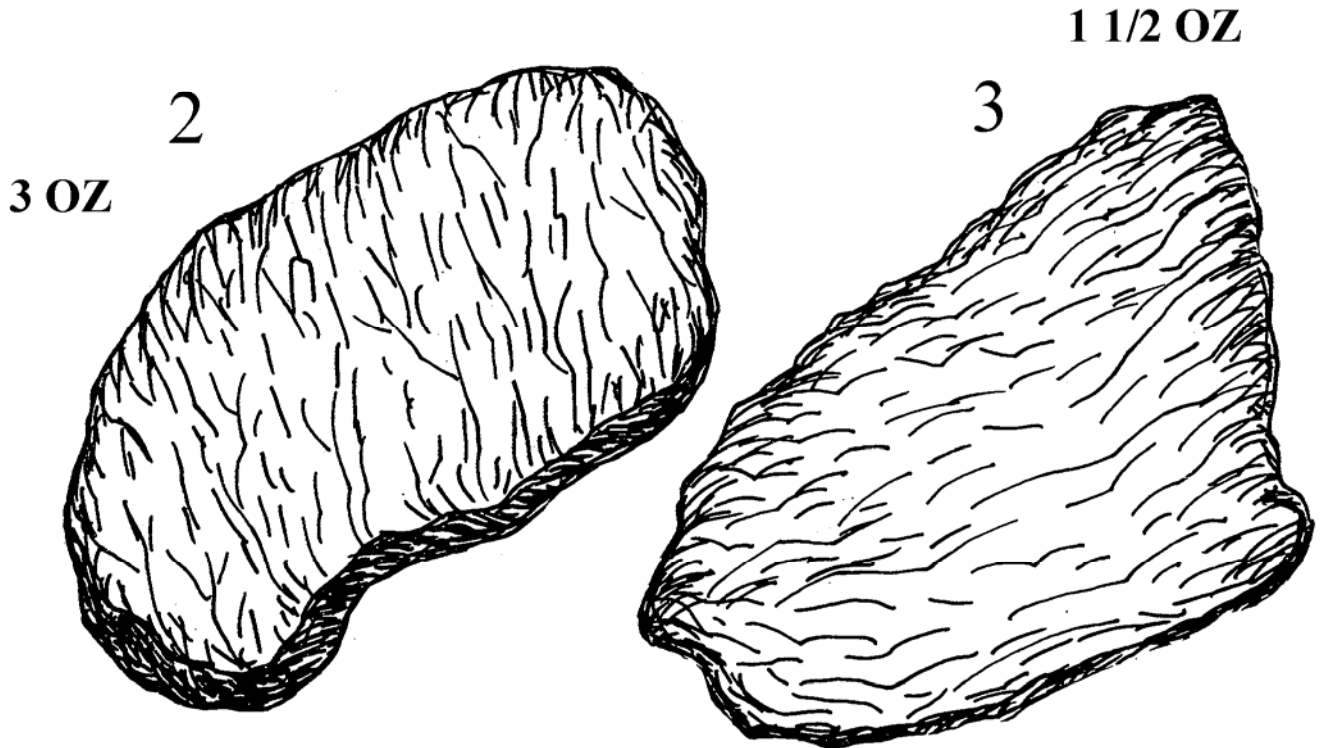
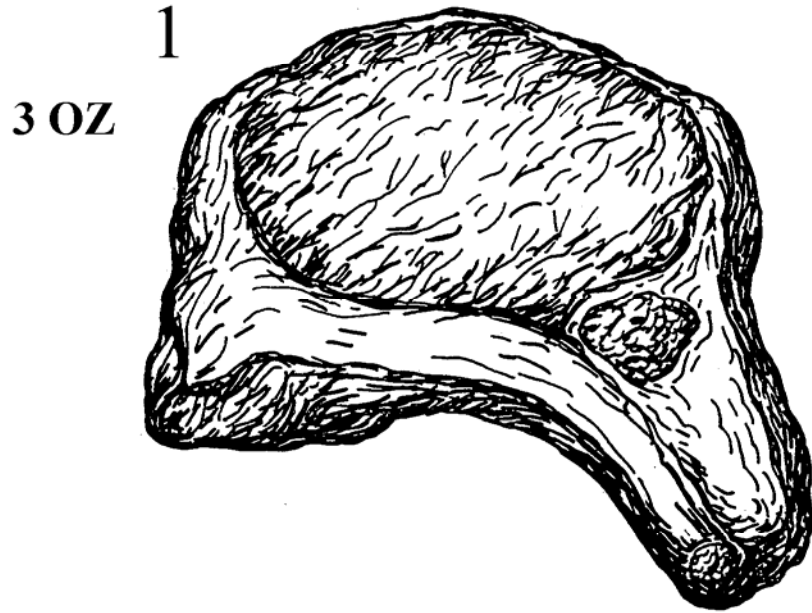

Chicken

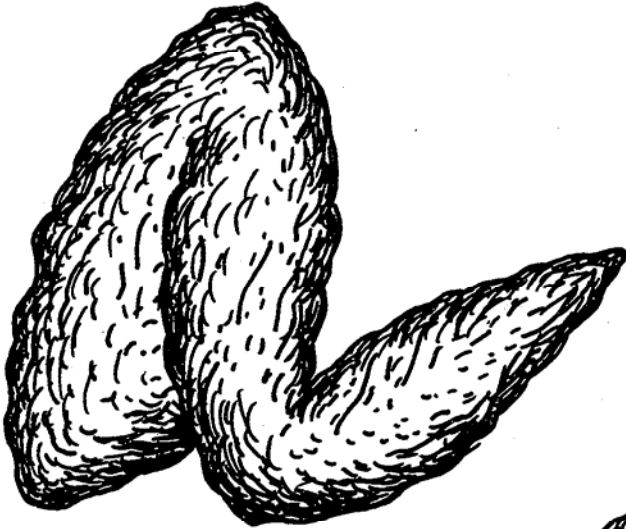

1. Wing

MD

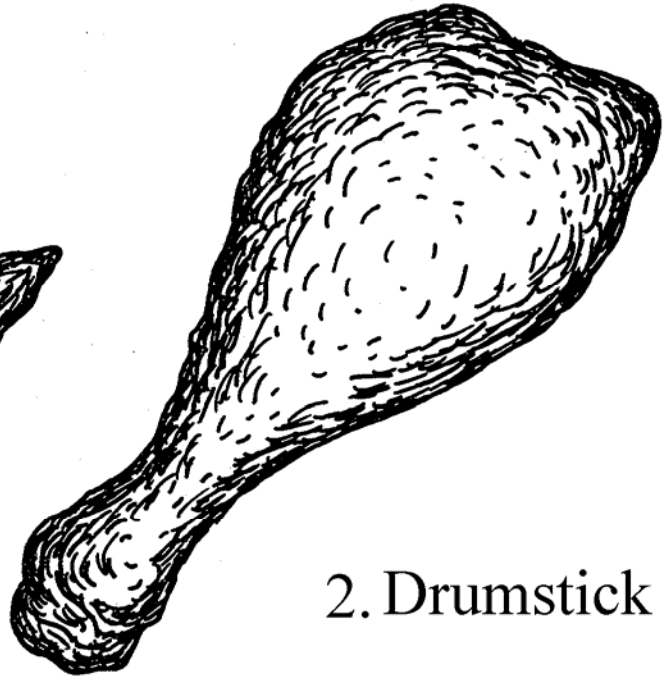

2. Drumstick

MD

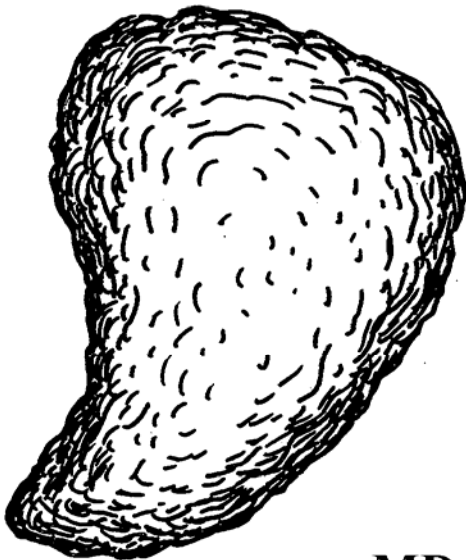

3. Thigh

MD



4. Breast

MD

Fish

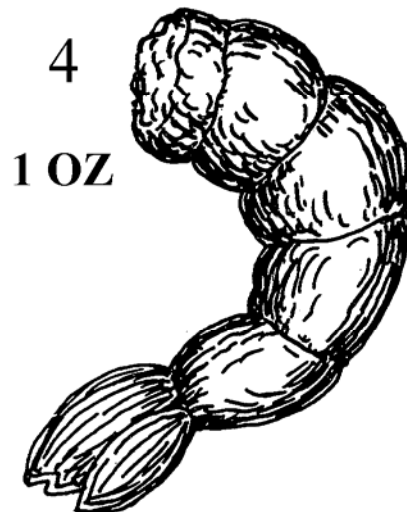
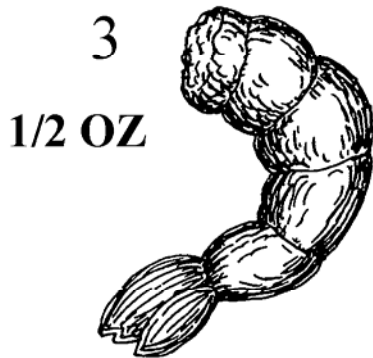
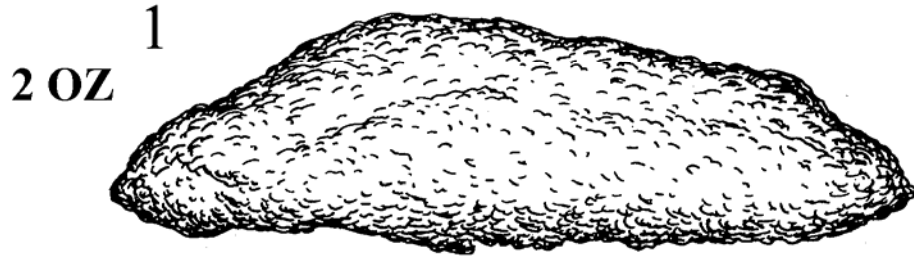

Adapted from: Van Horn LV, Stumbo P, Moag-Stahlberg A, Obarzanek E, Hartmuller VW, Farris RP, Kimm SY, Frederick M, Snetselaar L, Liu K. The Dietary Intervention Study in Children (DISC): dietary assessment methods for 8- to 10-year-olds. *J Am Diet Assoc.* 1993 Dec;93(12):1396-403.
Modified by Alejandra Valencia, Mary Stevens, Nutrition Coordinating Center, University of Minnesota for the Hispanic Community Health Study, Study of Latinos, 2007.